

Tractor dump trailer 2PTS-4,5

The trailer is designed to transport various agricultural goods on all types of roads and in the field. Transportation of bulk building materials is allowed, with the exception of rocks and cobblestones.

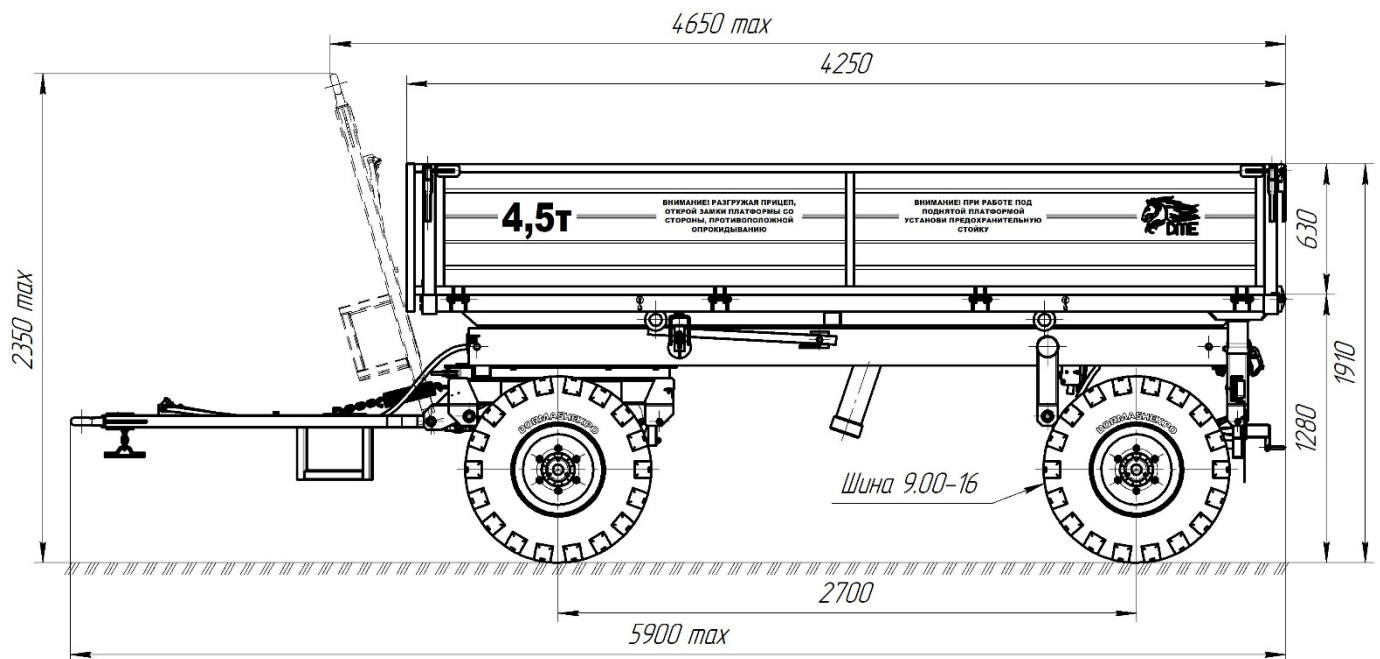

Technical characteristics

Parameter	Value
1 Type	Trailer
2 Tractor drawbar category	1,4-2
3 Trailer category	Ra3
4 Lifting capacity, kg, max	4 500
5 Max speed, km/h	
- transport mode	30
- working mode	18
6 Axle number, pcs.	2
7 Wheels per axle, pcs.	2
8 Wheel base, mm, min	2 700
9 Unloading sides	3
10 Tires / pressure, MPa	
- basic	9.00-16 PR10 / 0,35
- option 1	10.0/75-15.3 PR10 / 0,39
- option 2	13.0/75-16 PR8 / 0,24
11 Weight, kg, max	
- design gross weight (without options with basic tires)	1 810
- full weight (technical permissible)	6 370
12 Weight distribution per axle, kg, max	
- axle Nr. 1	3 200
- axle Nr. 2	3 170

13	Overall dimensions, mm, max - length - width - height - with basic tires - with optional tires 1 - with optional tires 2	5 900 2 310 1 910 1 840 1 910
14	Track width, mm, min - with basic tires - with optional tires 1 - with optional tires 2	1 850 1 850 1 930
15	Inner body dimensions, mm, max - length - width	4 050 2 130
16	Sides height, mm, max	630
17	Body floor surface, m ² , max	8,63
18	Body volume, m ³ , max	5,43
19	Ground clearance, mm, min	310
20	Body floor loading height with basic tires, mm, max	1 280
21	Body tipping angle, degrees, min	45
22	Body tipping time, s, max	50
23	Hydraulic system working pressure, MPa, max	20
24	Manning level, persons	1
25	Working brake system - brake axle number - brake mechanism type - brake activation type - brake system scheme	1 drum pneumatic single line
26	Parking brake system	mechanical with manual drive
27	Lifetime, years, min	8

