

## TRACTOR DUMP TRAILER 2PTS-6,5N (with full metal put-on sides)

The trailer is designed to transport various agricultural goods, like manure, sawdust, gravel, wood chips, compost, silage, grain, beetroots, on all types of roads and in the field. Transportation of bulk building materials is allowed, with the exception of rocks and cobblestones.

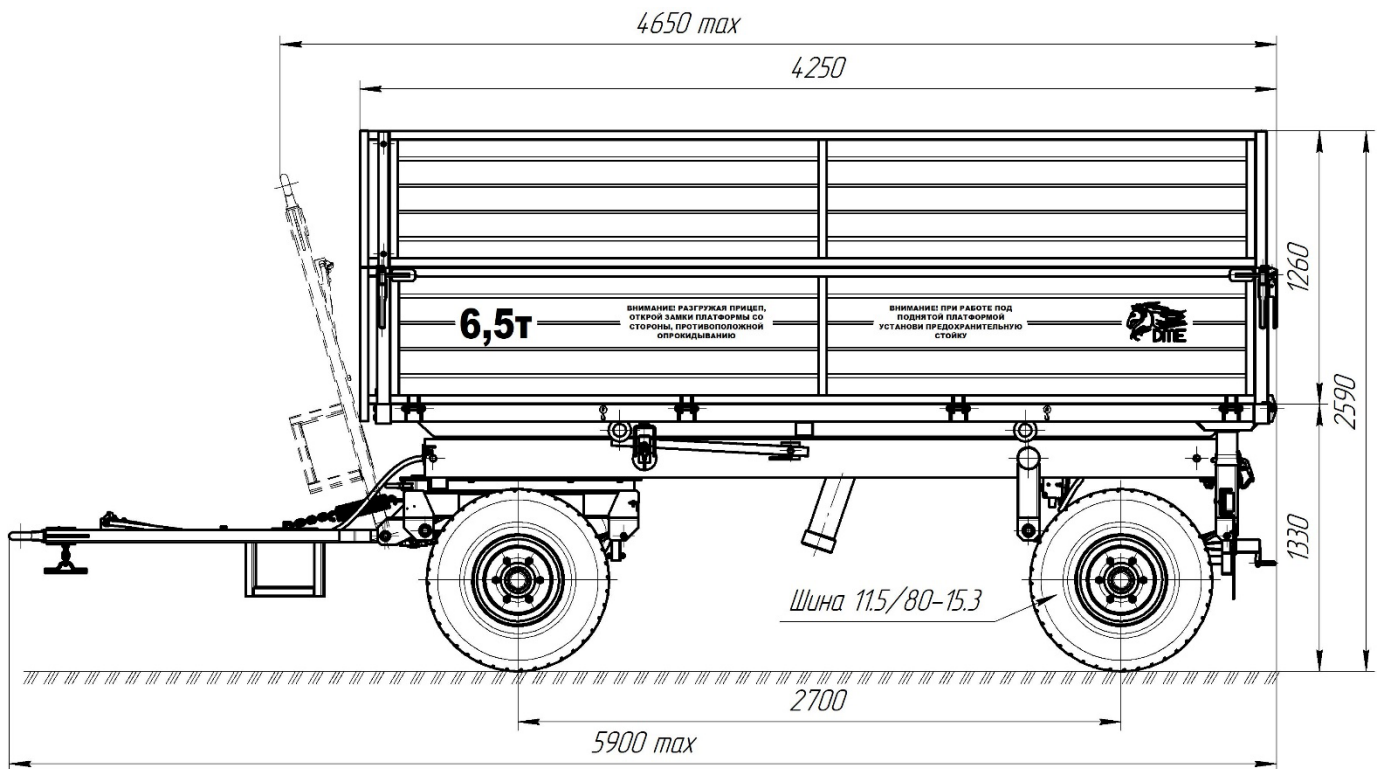

### Technical characteristics

Parameter	Value
1 Type	Trailer
2 Tractor drawbar category	1,4-2
3 Trailer category	Ra3
4 Lifting capacity, kg, max	6 500
5 Max speed, km/h	
- transport mode	30
- working mode	18
6 Axle number, pcs.	2
7 Wheels per axle, pcs.	2
8 Wheel base, mm, min	2 700
9 Unloading sides	3
10 Tires / pressure, MPa	
- basic	11.5/80-15.3 PR14 / 0,475
- option 1	12.5/80-15.3 PR14 / 0,43
- option 2	13.0/75-16 PR14 / 0,37
11 Weight, kg, max	
- design gross weight (without options with basic tires)	2 120
- full weight (technical permissible)	8 670

12	Weight distribution per axle, kg, max - axle Nr. 1 - axle Nr. 2	4 510 4 160
13	Overall dimensions, mm, max - length - width - height - with basic tires - with optional tires 1 - with optional tires 2	5 900 2 310 2 590 2 615 2 620
14	Track width, mm, min - with basic tires - with optional tires 1 - with optional tires 2	1 850 1 850 1 930
15	Inner body dimensions, mm, max - length - width	4 050 2 130
16	Sides height, mm, max	1 260 (630+630)
17	Body floor surface, m <sup>2</sup> , max	8,63
18	Body volume, m <sup>3</sup> , max	10,87
19	Ground clearance, mm, min	310
20	Body floor loading height with basic tires, mm, max	1 330
21	Body tipping angle, degrees, min	45
22	Body tipping time, s, max	50
23	Hydraulic system working pressure, MPa, max	20
24	Manning level, persons	1
25	Working brake system - brake axle number - brake mechanism type - brake activation type - brake system scheme	2 drum pneumatic single line (dual line on request)
26	Parking brake system	mechanical with manual drive
27	Lifetime, years, min	8

