

TRACTOR DUMP TRAILER 2PTS-6,5RTP grain carrier
(with lower put-on sides, tarp on frame and screw grain conveyor)

This trailer is mainly used for grain transportation. Designed for grain transportation (grain crops). Transportation of wholesale packaging is allowed. Transportation of other various agricultural goods is allowed, taking into account the purpose of the trailer and its technical characteristics.

The trailer is equipped with a tarp with a reeling handle. The tarp is installed on a special frame that prevents the accumulation of water. The tailgate is equipped with a special window and grain loader on it (slide gate when no loader).

Side walls can be opened down and up by special locking system with manual handle in the lower part of the side walls. Put-on sides are locked.

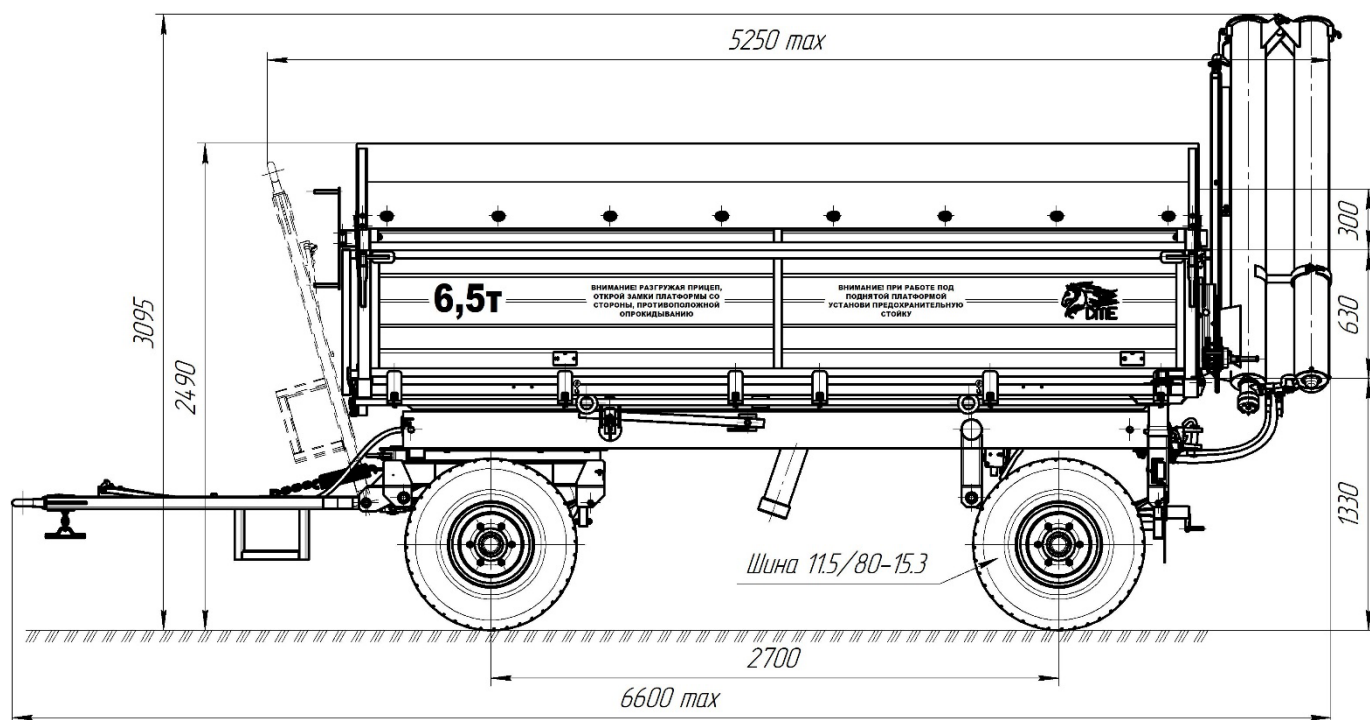

Technical characteristics

Parameter	Value
1 Type	Trailer
2 Tractor drawbar category	1,4-2
3 Trailer category	Ra3
4 Lifting capacity, kg, max	6 500
5 Max speed, km/h	
- transport mode	30
- working mode	18
6 Axle number, pcs.	2
7 Wheels per axle, pcs.	2
8 Wheel base, mm, min	2 700
9 Unloading sides	3

10	Tires / pressure, MPa - basic - option 1 - option 2	11.5/80-15.3 PR14 / 0,475 12.5/80-15.3 PR14 / 0,43 13.0/75-16 PR14 / 0,37
11	Weight, kg, max - design gross weight (without options with basic tires) - full weight (technical permissible)	2 310 8 860
12	Weight distribution per axle, kg, max - axle Nr. 1 - axle Nr. 2	4 470 4 390
13	Overall dimensions, mm, max - length - width - height - with basic tires - with optional tires 1 - with optional tires 2	6 600 2 310 3 095 3 120 3 125
14	Track width, mm, min - with basic tires - with optional tires 1 - with optional tires 2	1 850 1 850 1 930
15	Inner body dimensions, mm, max - length - width	4 050 2 130
16	Sides height, mm, max	930 (630+300)
17	Body floor surface, m ² , max	8,63
18	Body volume, m ³ , max	8,0
19	Ground clearance, mm, min	310
20	Body floor loading height with basic tires, mm, max	1 330
21	Body tipping angle, degrees, min	45
22	Body tipping time, s, max	50
23	Hydraulic system working pressure, MPa, max	20
24	Manning level, persons	1
25	Working brake system - brake axle number - brake mechanism type - brake activation type - brake system scheme	2 drum pneumatic single line (dual line on request)
26	Parking brake system	mechanical with manual drive
27	Lifetime, years, min	8

